

SUPERNET

10" DIGITAL RADAR LINE

GEM Digital Radar Line (DRL) provides impressive performances and a flawless radar video image thanks to its new architecture featuring a super compact DSP video processor board and enhanced networking capabilities.



Display 10 with Optical Bonding Technology

With DRL the following capabilities are ready to use:

- **Multi-display and multi-scanner configuration:** to dynamically configure any ship radar system with several displays and scanner units. Each scanner can be controlled in real time by the operator from any of the display unit (master configuration), while the other displays can independently show either the same (repeater mode) or any other different picture.
- **On-demand display assignment:** each display in the network can be independently and autonomously assigned by the operator to show the radar image, the video plotter or an overlay of combined radar-plotter image without interrupting navigation surveillance.
- **OEM Applications:** GEM elettronica software drivers allow scanner unit to be connected directly to standard PC using the RJ45 Ethernet port without any PC add-on hardware or external interfaces boxes. Drivers are available for Microsoft Windows XP and 7.



Order Code	GEM P/N	Display Unit	Display	Instr. Range	Display Resolution	Antenna Unit	Scanner Unit	Standard length of installation cable
10240RD/P	PF121300	DU68-10	10.4", LCD, TouchScreen	1/16 to 36nm	640x480 pixels	SU82-02		10 mt
10460RD/P	PF121310			1/16 to 48nm		SU82-12		
1044/P	PF121350			1/16 to 64nm		AU11-04N	SU78-14E	
1044/P/B	PF121351						SU78-14E/B	
1046/P	PF121360					AU11-06N	SU78-14E	
10124/P	PF121370			1/16 to 72nm		AU11-04N	SU70-14E	
10126/P	PF121380					AU11-06N		
10254/P	PF121450			1/16 to 96nm		AU11-04NA	SU70-25E	
10256/P	PF121460					AU11-06N		
10257/P	PF121470					AU11-07N		

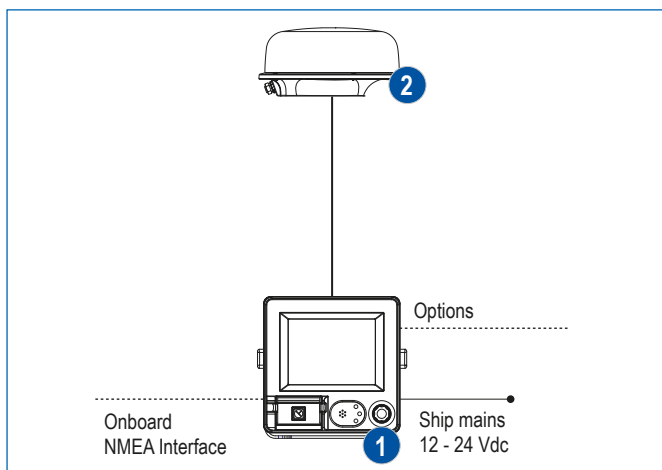

- 1 10" SUPERNET UNIT
- 2 4 kW RADOME

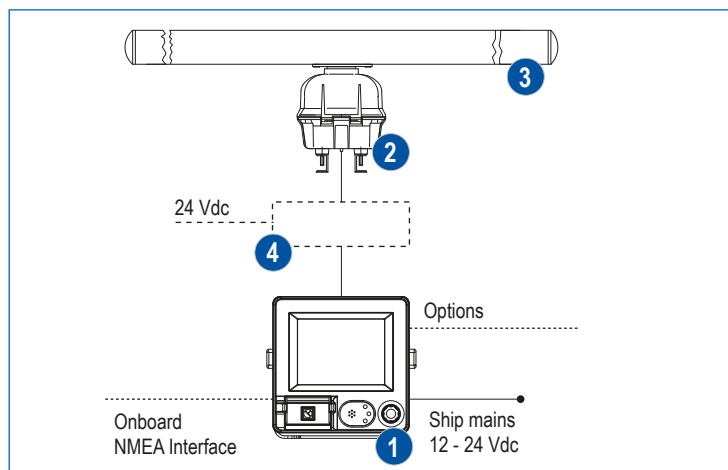

- 1 10" SUPERNET UNIT
- 2 4, 12 or 25 kW SCANNER UNIT
- 3 4, 6 or 7.5' ARRAY
- 4 ASU-41000 (case of 25 kW Scanner)

Options

HUB LINK SUPERNET 310

HUB LINK SUPERNET 620

Power supply cable

Connection cable between HUB (RJ45) and SUPERNET display, 1 mt / 5 mt / 20 mt / 30 mt

LAN connection Display-Display SUPERNET J6-J6, 5 mt / 10 mt / 20 mt / 30 mt

ETHERNET cable for connection between HUB and PC

Power supply cable DISPLAY and RADAR BOX complete with fuse

Fuse for new generation GEM cable 5 mt

Cable for interface with autopilot, fluxgate compass, GPS, AIS, external alarm, J3, J4, J5 connectors, 5 m / 10 m

Connection cable J5 with ECHO BOX, 5 mt / 10 mt

DATA CONCENTRATOR

Connections with EM cable for J3, J4 or J5 (same part number)

AC/DC CONVERTER

For radome type SP 100-12 Input 88-264 Vac 50 Hz, output 12 Vdc \pm 2%

For open antenna type SP 320-24 Input 88-264 Vac 50 Hz, output 24 Vdc \pm 2% 13 A

CONNECTION CABLES AND ACCESSORIES FOR SUPERNET AND RADAR BOX SYSTEMS

Connection cable between Radome and SUPERNET Display Unit, 15 mt length

Connection cable between Radome and HUB, 15 mt length

Keyboard with cable, 1.5 mt / 5 mt / 10 mt

Connection cable between Scanner and SUPERNET Display Unit, 15 mt length

Connection cable between Radome antenna and HUB, 15 mt length

C-MAP External C-Card reader

Cartography C MAP-MAX

LOCAL

WIDE

MEGA WIDE

SUPERNET

10" DISPLAY

Data Display Capabilities	Chartplotter, Radar
Display (LCD) size	10.4" Touch Screen
Display colors	256
Display resolution	640 x 480 pixels (VGA)
Display type	Transflective color TFT LCD
Interfaces	3 NMEA 0183, 1 auxiliary Ethernet LAN
SpeakVoice	for warning, alarm and instructions
Mounting Methods	See Outline drawing
MiniARPA	capability of manual/automatic acquisition and automatic tracking of 12 targets
AIS	50 targets, AIS ATon targets, (sensor required)

ENVIRONMENTAL AND SUPPLY





Temperature (IEC 60945) - 15°C to 55°C (display)	- 25°C to 55°C (External Unit)
Enclosure	Waterproofing IPX5
Power Voltage	12 to 24 Vdc Radome - 24 Vdc Open antenna
Power consumption	< 70 W

INSTALLATION KIT

Installation GEM cable	10 mt.
Kit of ancillaries, installation and operator manual	



radar / plotter

-  10.4" TouchScreen
-  User friendly
-  Ethernet LAN
-  Universal mounting
-  Personal colours

Display: DU68-10



Radome: SU82-02



Radome: SU82-12



Open array and Scanner aspect

ANTENNA	Radome 46	Radome 62	4 ft Array	6 ft Array	7.5 ft Array
Length	1.4 feet	1.8 feet	4 feet	6 feet	7.5 feet
Type	Microstrip Array		Slotted waveguide		
Frequency band	9410 ± 50 MHz.				
Polarization	Horizontal				
Horizontal beamwidth	5.2° ± 0.2°	3.8° ± 0.2°	1.8° ± 0.1°	1.2° ± 0.1°	1.05° ± 0.1°
Vertical beamwidth	25° ± 2°	25° ± 2°	22° ± 2°	22° ± 2°	22° ± 2°
Sidelobes within ± 10°	-19 dB	-19 dB	-26 dB	-26 dB	-26 dB
Sidelobes outside ± 10°	-21dB	-21dB	-30 dB	-30 dB	-30 dB
Gain	≥ 19 dBi	≥ 21 dBi	≥ 27dBi	≥ 29 dBi	≥ 30 dBi

TRANSCEIVER UNIT	Radome		Scanner		
Peak power (nominal):	4 kW		12 kW	25 kW	
Range scale:	36 nm	48 nm	64 nm	72 nm	96 nm
Radiation frequency:	9410 ± 30 MHz.				
Pulse Width:	50 nS	50 nS	50 nS	50 nS	80 nS
	80 nS	80 nS	200 nS	200 nS	200 nS
	300 nS	300 nS	400 nS	400 nS	400 nS
	800 nS	800 nS	800 nS	800 nS	800 nS
	(± 20nsec; for PW > 300nsec ± 10% tolerance)				
Pulse Repetition Frequency:	2600 Hz	2600 Hz	3200 Hz	3200 Hz	2000 Hz
	2100 Hz	2100 Hz	1600 Hz	1600 Hz	1000 Hz
	1200 Hz	1200 Hz	800 Hz	800 Hz	750 Hz
	600 Hz	600 Hz	500 Hz	500 Hz	500 Hz
	(with ± 5% tolerance – stagger function included)				
Transmitter type:	Magnetron				
Modulator:	fully solid state				
Receiver type:	logarithmic, fully solid state				
Dynamic range:	100 dB				
Intermediate Frequency (I.F.):	60 MHz ± 2 MHz				
I.F. bandwidth:	20 MHz with short and medium pulses 4 MHz with long and extralong pulses (with ± 10% tolerance)				
Minimum Detection Range	< 15 m from the antenna location				
Noise Figure:	Nominal 3.5 dB				
Antenna rotation speed:	Radome: 24/30 (> 1.5 nm) rpm - Open array: 22 ± 2 rpm - River: 36 rpm				



DU68-10 Embedded Horizontal installation
278.2

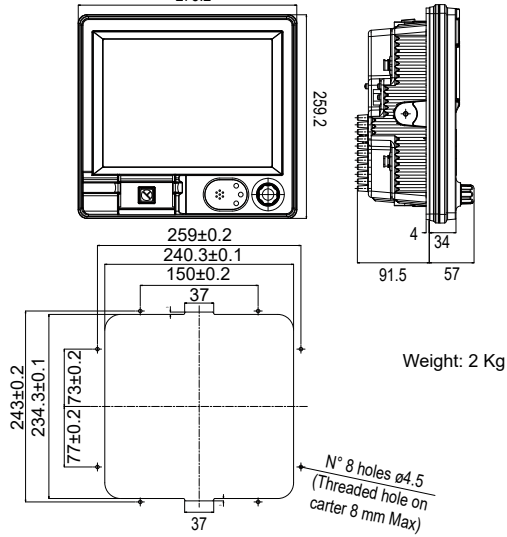

DU68-10 Vertical installation with bracket

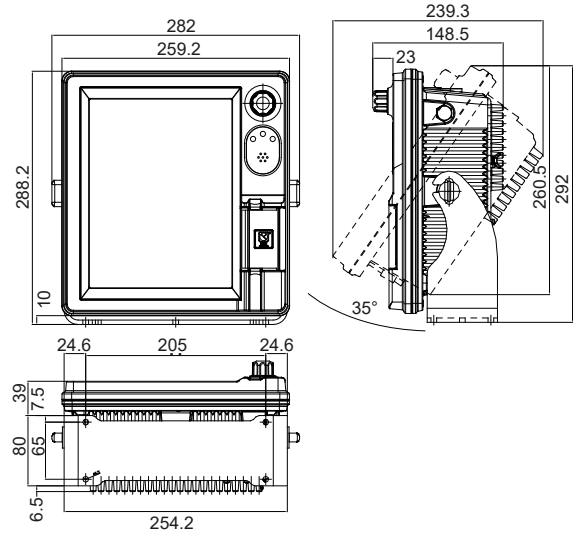

SU82-02 Mechanical installation

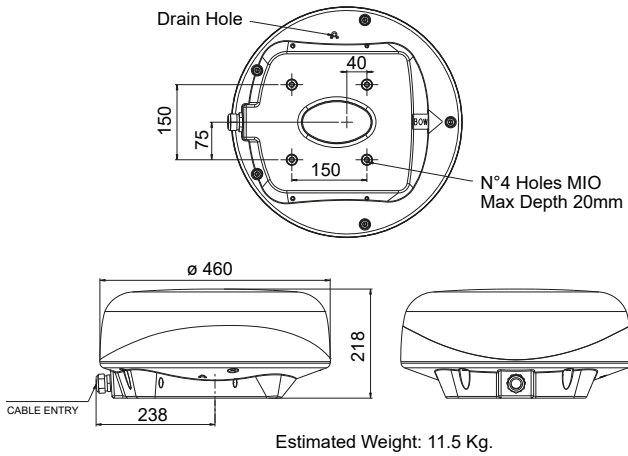

SU82-12 Mechanical installation

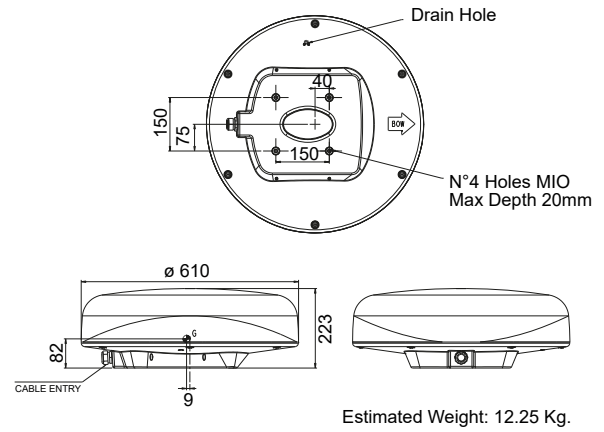

AU11-04N/AU11-04NA
AU11-06N
AU11-07N

4 feet (1400 mm)
6 feet (1940 mm)
7.5 feet (2210 mm)

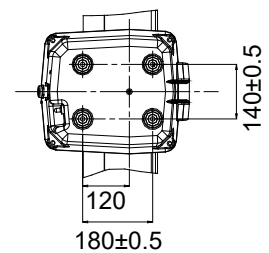
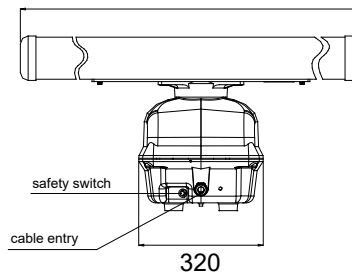
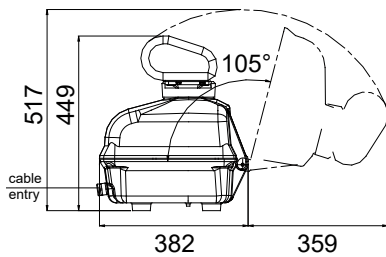

Estimated Weight

4' ANTENNA UNIT	3.8 kg.
6' ANTENNA UNIT	5.8 kg.
7.5 ANTENNA UNIT	11 kg.
SCANNER UNIT	14.5 kg.

SU78-14E
SU78-14E/B
SU70-14E
SU70-25E

Surveillance & Security

Guidance, Navigation & Positioning

Military & Defence

Marine Electronics

This brochure should not be considered a contractual offer to sell. The specifications given herein may be changed by the manufacturer, GEM elettronica S.r.l., without notice.

