

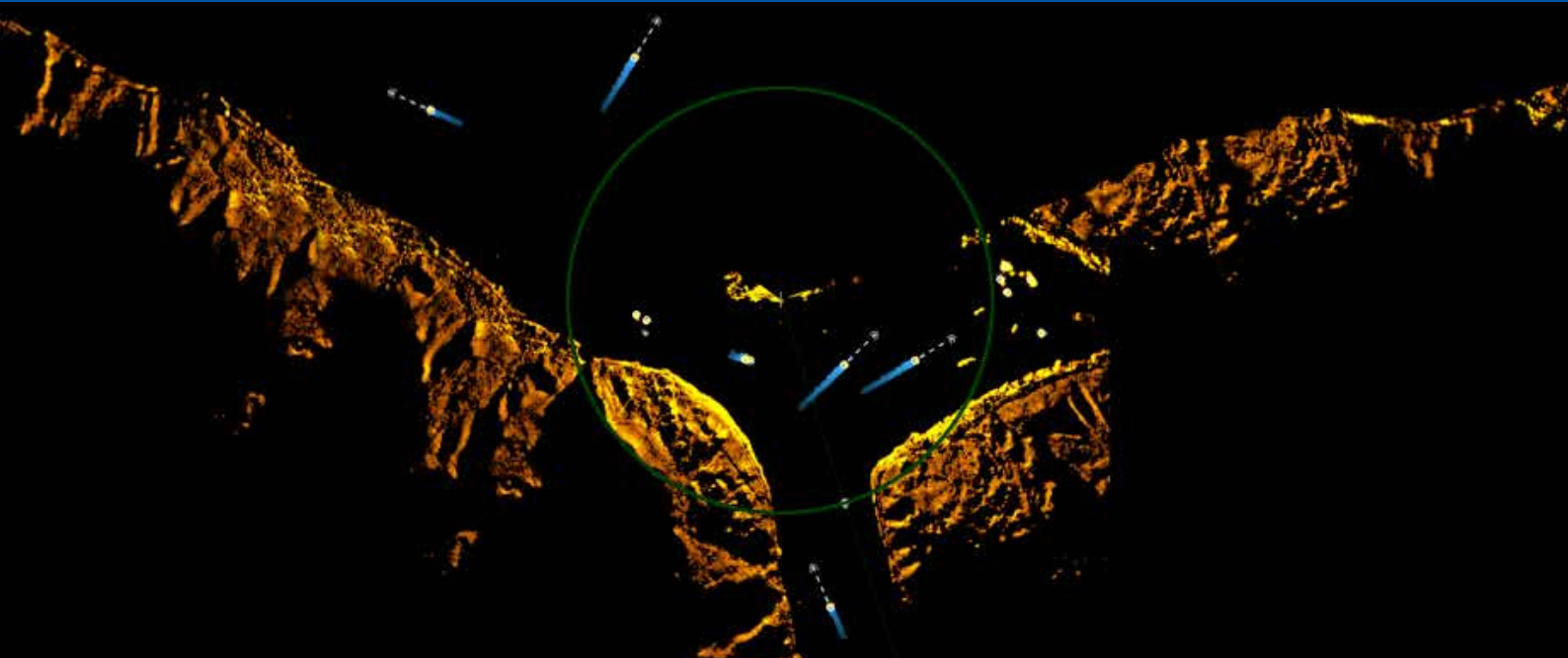

Olympus

NEW BORN FROM **Sentinel** FAMILY

RADAR SYSTEM FOR COASTAL SURVEILLANCE AND VTS



Evolution of the SENTINEL family, the OLYMPUS family summarizes all the design innovations of our passionate engineering for the creation of a radar with even better performances and unmatched reliability thanks to the latest hardware, software and mechanical solutions needed for the heaviest applications.

GEM elettronica develops and manufactures products to provide world-class surveillance systems. Olympus Radar system is the latest addition to GEM elettronica's Surveillance & Security product portfolio. It has been designed to fully meet the **demands of the latest IALA V-128 Guidelines for Coastal surveillance and VTS applications**. It is tailored for professional customers such as Coast Guards, Port and Airport Authorities, Oil & Gas Companies. *The Defense customers can use Olympus Radar System for Coastal Surveillance applications and Naval Bases protection requiring a system with high operational performance and high reliability operation.*



Olympus can be delivered in various configurations compliant with the **Basic, Standard or Advanced** systems in accordance with IALA N.1111 Guideline.





M A I N D E S I G N C O N S I D E R A T I O N S

FULLY COHERENT, FULLY SOLID STATE PULSE COMPRESSION RADAR

Olympus radar system is an X-band, fully coherent, fully solid state, pulse compression radar. It provides high detection performance with unique and outstanding capabilities, utilizing new Solid State technologies and high speed processor that enables fast processing and complex performance. The innovative Transmitter/Receiver with High Dynamic Range and Software Defined Functionality, includes video processing techniques such as Frequency Diversity, Time Diversity, CFAR and Doppler Filtering.

HIGH LEVEL OF DETECTION

A high gain antenna allows Olympus to detect very small targets on the sea surface and shows echoes with crisp images, whether the targets are moving very fast around the radar site or located miles away. Olympus can also support Search & Rescue operations as it is able to see short range targets that flies at low altitude.

ALL RADAR TRACK DATA AVAILABLE (Optional)

In operational use, Olympus offers continuous surveillance. With automatic start of the "Track- While-Scan" the radar allows: detection, extraction of plot and tracking of more than 1000 surface targets with high discrimination at long range.

ABSOLUTE RELIABILITY FOR ANY ENVIRONMENT

The new Antenna Unit developed in-house has been designed for missions that require high efficiency operation, extreme rotation performance, strength and durability in harsh environmental conditions.

EXTRAORDINARY ELECTROMECHANICAL PERFORMANCE

The pedestal is equipped with a direct drive system with torque motor and high resolution encoder. Thanks to its backlash free structure, Olympus offers superior performance by providing extraordinary azimuth precision, high range resolution as well as extremely low-level noise. Olympus allows to stop the rotation of the antenna in any position set by the operator. There is also a mechanical block of the antenna allowing to perform local maintenance operations in complete safety.

INTEROPERABILITY

Olympus Radar System does not only support local surveillance but interfaces to other IP based sub-systems as well. It can be controlled remotely and can output video, plots, tracks and status, all via LAN. Olympus uses the Asterix protocol for data transmission.

HIGH SYSTEM AVAILABILITY & LOW MAINTENANCE COST

Olympus guarantees high reliability and long operational life, low maintenance and low life cycle cost. The radar has been designed and built to operate reliably 24/7 all year round, with full operational performances even in the most adverse environmental conditions. The calculated inherent system availability is over 99%. Olympus has been specifically engineered to guarantee easy maintenance operations. The self-diagnostic program (BITE) incorporated in the radar, is supported by a simple maintenance philosophy, which allows rapid replacement of modular sub-assemblies and improved maintainability.

Olympus



BENEFITS & FEATURES

- Third generation of new stabilized Solid State Amplifiers up to 400 W, designed in house.
- Fully digital configuration available through Software Defined Functionality.
- Time and Frequency Diversity techniques in Frequency Diversity mode with automatic adaptation to the real scenario.
- MTI/Doppler target detection for clutter suppression. It allows outstanding performance of detection and tracking of small and fast surface targets also in condition of sub-clutter visibility.
- Can be remotely accessed and controlled.
- User-defined profiles of operation
- Torque Direct Drive Motor and Very High Resolution Coaxial Optical Encoder to ensure extraordinary accurate detection of the angular position of the radar antenna. *(Option Dual Encoder)*.
- Tracker compliant to IALA Guideline 1111, 2015 Top Performance. It ensures the connection to the external world and allows fully remote control of each radar heads through its LAN interface module. *(Option)*
- Dual Redundant or Frequency Diversity downmast transceiver in one chassis only
- Programmable blanking sector
- Automatic and continuous detection and tracking with high range and azimuth accuracy.
- Digital and Network Video Distribution. ASTERIX on a LAN interface enables Ethernet communication.
- 365/24/7 uninterrupted operation in all weather conditions like heat freezing cold, humidity, sand and wind.
- Comprehensive Built-in-Test (BIT)
- Low Life Cycle Cost

CONFIGURATIONS

UPMAST

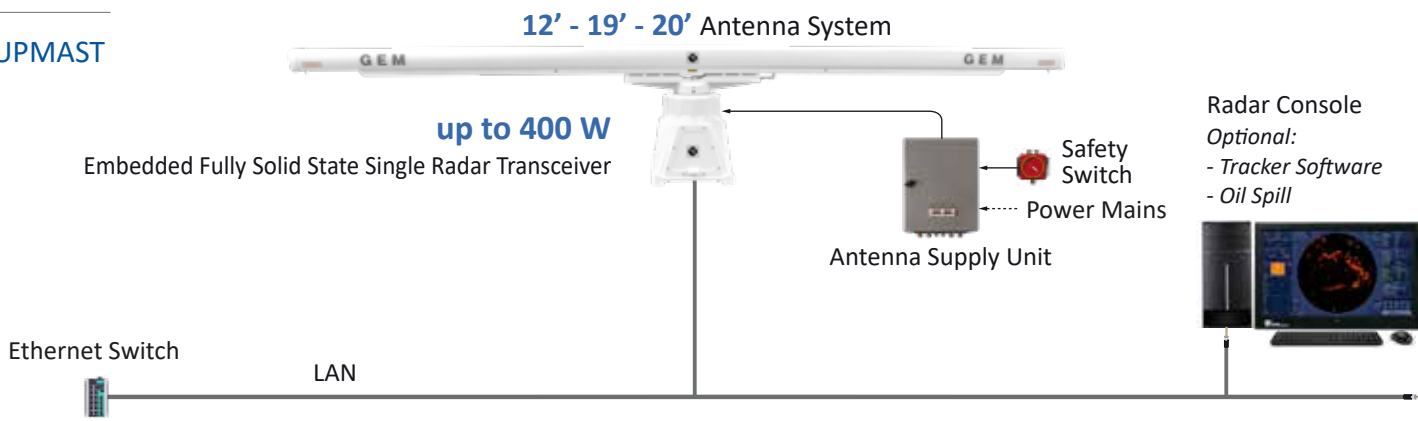

DOWNMAST SINGLE

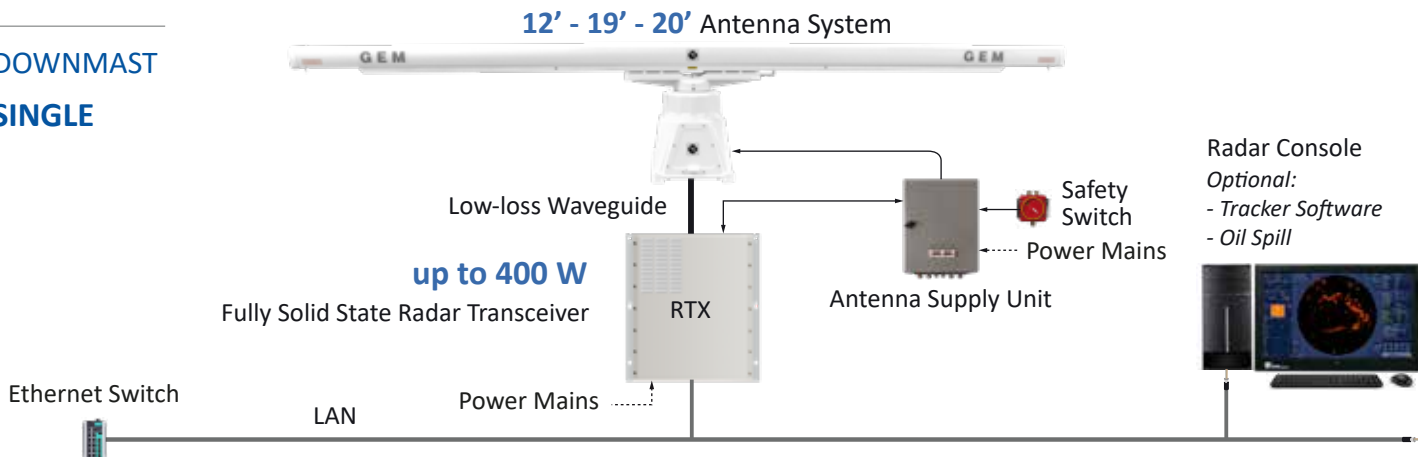

DOWNMAST DUAL REDUNDANT

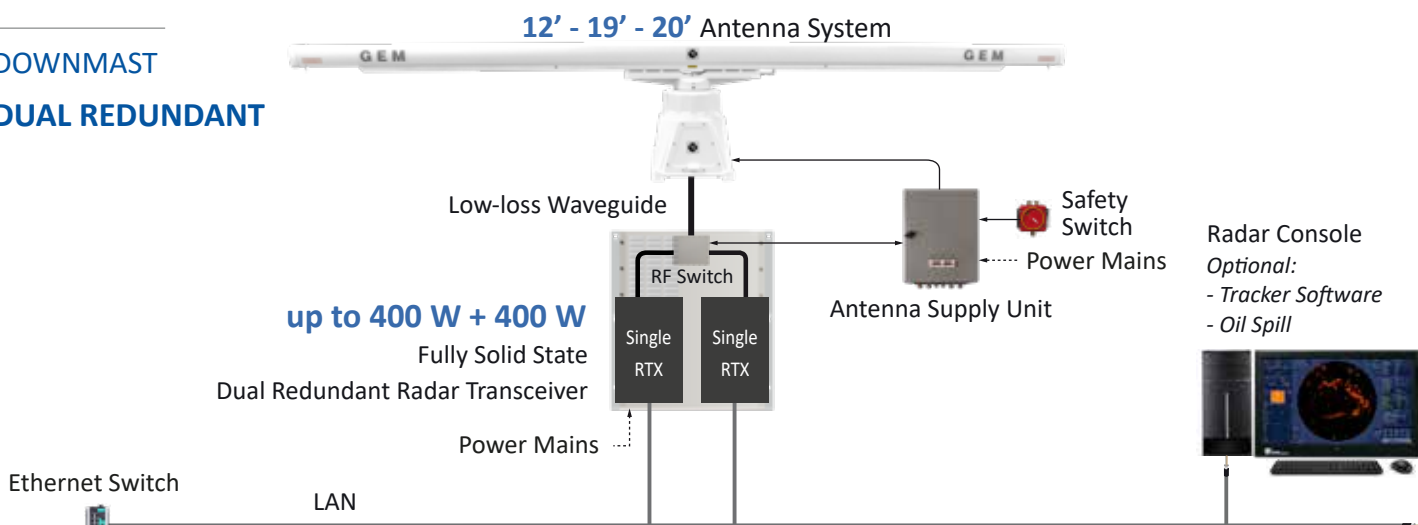

DOWNMAST FREQUENCY DIVERSITY

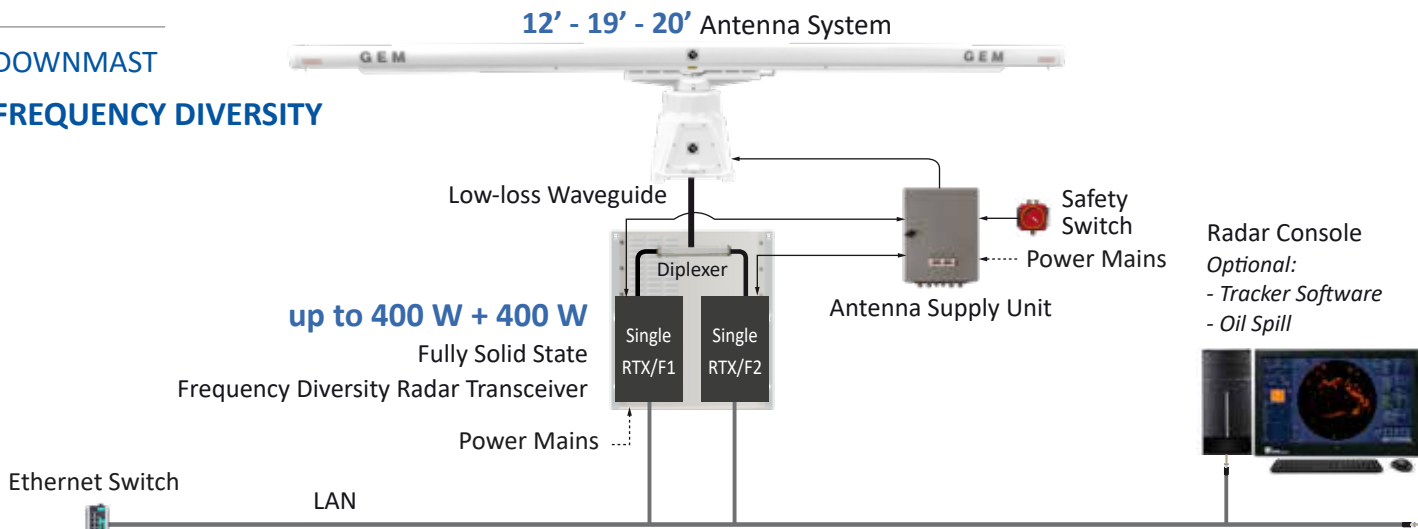

BASIC

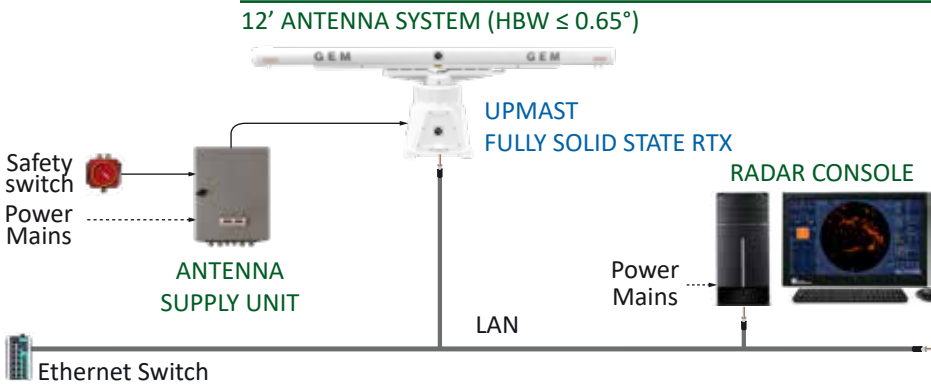

Available RTX configurations:

- Fully Upmast RTX, at least 100 W
- Downmast Dual Redundant RTX, at least 100 W
- Downmast Frequency Diversity RTX, at least 100 W

Available Antenna configurations:

- 12' Antenna System
- Horizontal or Circular polarization

STANDARD

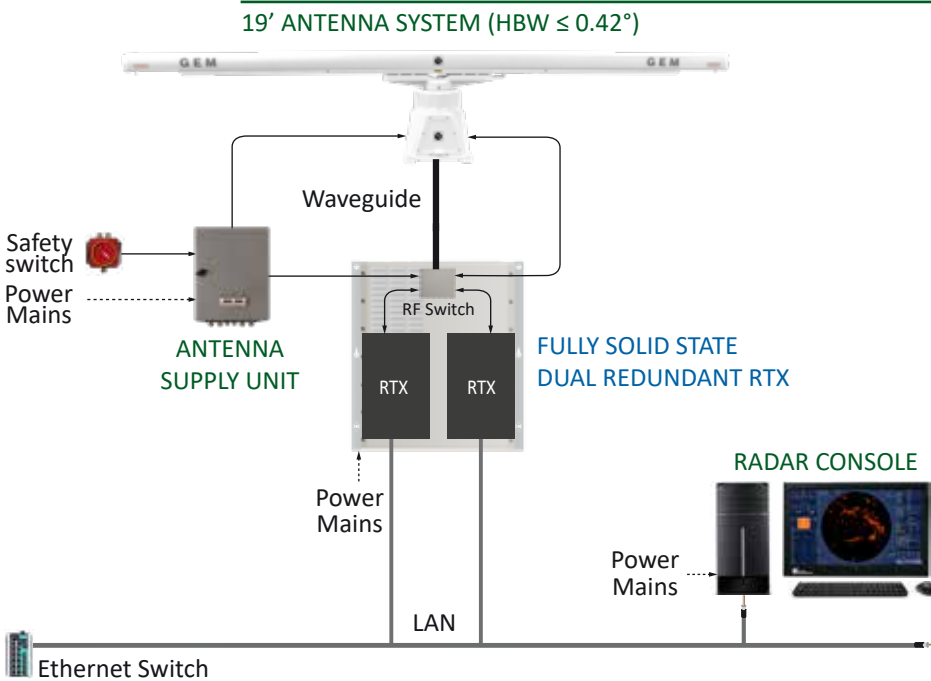

Available RTX configurations:

- Fully Upmast RTX, at least 200 W
- Single Bulkhead RTX, at least 200 W
- Downmast Dual Redundant RTX, at least 200 W
- Downmast Frequency Diversity RTX, at least 200 W

Available Antenna configurations:

- 19' Antenna System
- Horizontal or Circular polarization

ADVANCED

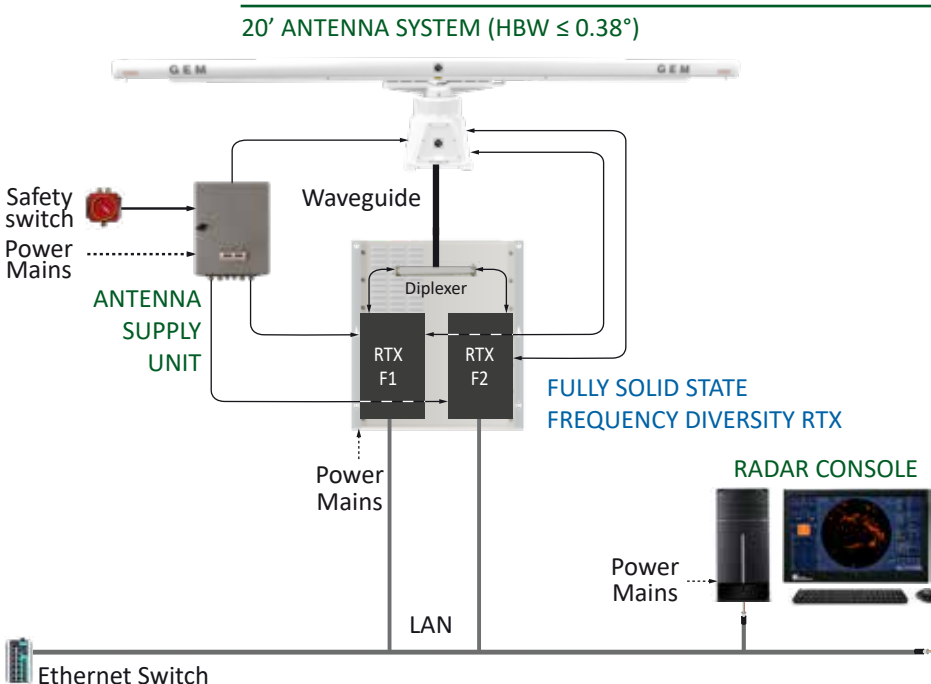

Available RTX configurations:

- Fully Upmast RTX, at least 200 W
- Single Bulkhead RTX, at least 200 W
- Downmast Dual Redundant RTX, at least 200 W
- Downmast Frequency Diversity RTX, at least 200 W

Available Antenna configurations:

- 20' Antenna System
- Horizontal or Circular polarization

	Standard	Optional
User facilities		
Programmable Blanking sectors	●	
Fully integrated BITE facility covering also RF sections	●	
Remote management during operation, local management for local assistance	●	
Interface		
1 GB LAN Ethernet (digitized video and controls)	●	
ASTERIX 240 (video)	●	
ASTERIX 253 (commands and states)	●	
Configurations		
Programmable operating frequencies within 9.0 - 9.5 GHz	●	
Upmast configuration: up to 400 W transmitted power	●	
Antenna: 12' / 19' / 20', Horizontal/Circular Polarization, up to 60 rpm	●	
Coaxial optical encoder: 4096/8192/16384 pulses/antenna revolution	●	
Dual Coaxial optical encoder: 4096/8192/16384 pulses/antenna revolution		●
Upmast / downmast RTX mounting	●	
Mechanical lock against antenna sailing		●
De-icing kit versus coldest environment		●
Environmental		
IEC 60068-2-2, IEC60068-2-1, IEC 60068-2-3, IEC 60068-2-9 test A, IEC 60945, IEC 60529, IEC 60945, IEC 60068-2-52	●	
Performances		
Radar Target Detection compliant to IALA Guideline N.1111, 2015	●	
Available Stagger function	●	
Radar signal pre-filtering, Doppler, and proprietary pulse compression techniques	●	
Receiver dynamics of 140 dB	●	
Diversity	●	
MTI optional		●
Tracker Software on Radar Console allowing manual or automatic tracking of 1000 targets		●
Oil Spill		●

The new Antenna Group developed in house has been designed for missions that require high efficiency operation, user selectable rotation speed, strength and durability in harsh environmental conditions. The pedestal is equipped with a direct drive system with torque motor and high resolution encoder. **Thanks to its backlash free structure, the antenna offers superior performance by providing extraordinary azimuth precision, high range resolution as well as extremely low-level noise.**

Olympus allows to stop the rotation of the antenna in any position set by the operator, thereby allowing to perform local maintenance operations in complete safety.



ANTENNA UNIT



Array Size	Length	Weight
12 feet	3830 mm	24 Kg
19 feet	5890 mm	65 Kg
20 feet	6154 mm	67 Kg

ANTENNA MOTOR UNIT

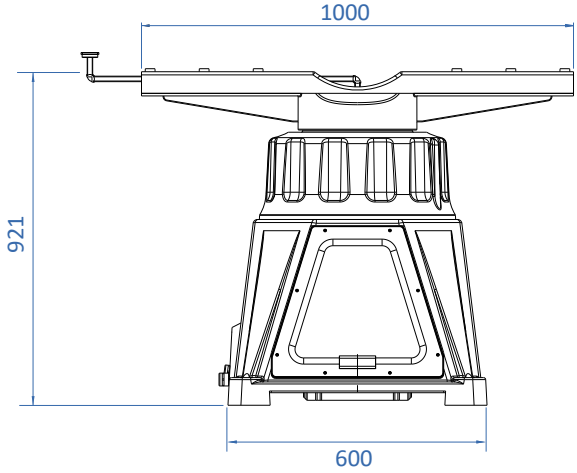

Weight: 150 Kg

DOWNMAST TRANSCIVER
Dependent on configuration

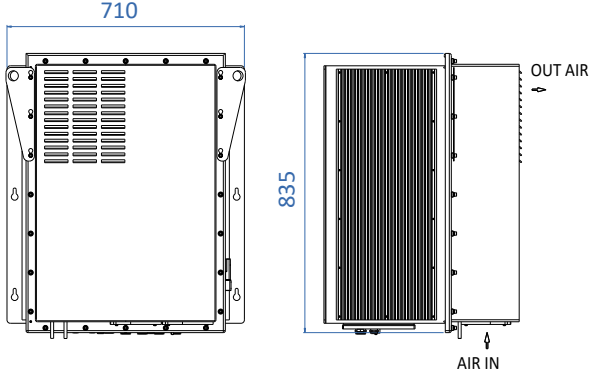

Weight: 80 Kg

ANTENNA SUPPLY UNIT

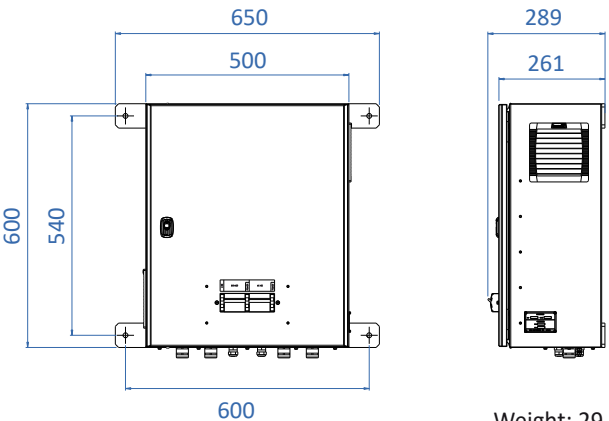

Weight: 29 Kg

SAFETY SWITCH

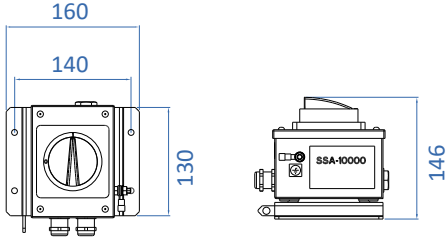

Weight: 2 Kg

