

ELECTRO-OPTICAL SURVEILLANCE SYSTEM

FEATURES

- Hi-Res MWIR camera and Day Light / Low Light cameras
- Laser illuminator allowing to read a ship's name with 0.5 m characters at a distance not less than 0.5 NM in total darkness
- Image blending: Blending between IR and Daylight camera
- Image functions: freeze frame, Picture in Picture, split screen



SUPPLY COMPOSITION

- Electro-Optical stabilized Turret with:
 - MWIR HD thermal imager
 - HD Day Light Camera / Low Light camera
 - SWIR spotter scope
 - Laser range finder
 - Laser illuminator (option)
- Rugged Motion Control Unit
- Installation kit
- Technical manual of the system in English language
- Certificate of conformance
- Packing list



Dynamic features

Control angle:
 Azimuth: Continuous N x 360° (with slip-ring)
 Elevation: -20° to +70°
 Slewing Velocity: > 130°/s
 Stabilization error: better than 50 µrad

MWIR HD thermal imager

Detector Type: cooled FPA 10 µm pixel pitch
 Resolution: 1280 x 720
 Spectral band: 3÷5 µm
 Lens: 18÷330 mm, continuous zoom, F/4
 Field of view (H): narrow (NFOV): 2.3°
 wide (WFOV): 39°

Optical zoom: > 18x
 Digital zoom: 1.5x / 2.0x / 4.0x
 Focus control: manual / automatic
 Cooler: Stirling microcooler
 Cooldown time: < 7 min @ 20°C
 NETS (sensitivity): ≤ 30 mK

Detection performance:

Target type	Detection	Recognition	Identification
Man (1.8 x 0.5m)	9.5 km	4.5 km	2.5 km
NATO (2.3 x 2.3m)	19.0 km	11.0 km	6.0 km

(Target ΔT ≥ 2°C)
 (Attenuation = 0.65 dB/km)

SWIR spotted scope

Wavelength: 1000÷1700 nm
 Sensor type: Indium Gallium Arsenide (InGaAs)
 Field of view (H): narrow (NFOV): ≤ 1°
 wide (WFOV): ≥ 30°
 Optical zoom: ≥ 30x
 Electronic zoom: 4x
 Gain Control: automatic

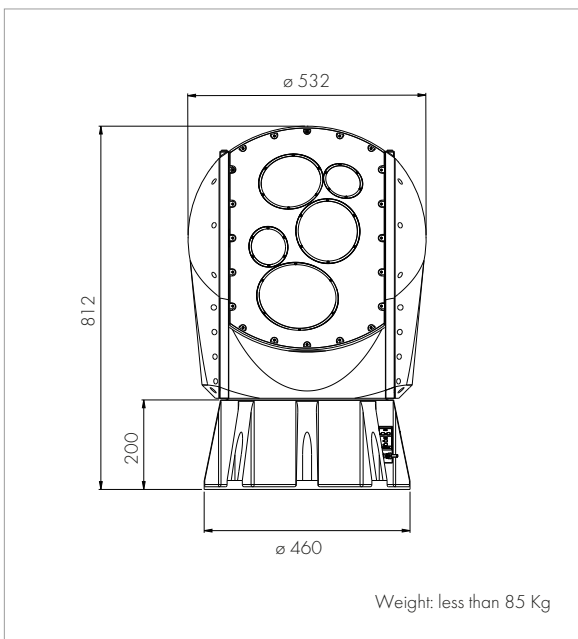

HD Day Light Camera / Low Light Camera

Image sensor: 1/1.8" 3M Pixel type lens
 Optical zoom: 31 x
 Max aperture ratio: Wide: F 1.55, Tele: F 4.80
 Number of pixels: 2064(H) x 1554(V)
 Pixel Size: 3.45 µm(H) x 3.45 µm(V)
 Scanning System: Progressive scan (Full HD:25/30/50/60 fps)
 Field of view (H): Wide (x1) 59.6°
 Tele (x31) 2.1°
 Focus: Auto focus
 Focus range: Wide side 1.5 m ~ ∞
 Tele side 1.5 m ~ ∞
 S/N ratio: 50 dB (rms) or better

Laser Range Finder

Transmitter type: flashlamp pumped Nd:YAG laser
 Wavelength: 1.57 µm, eyesafe (Class 1), linear polarization
 Receiver type: APD photo diode based type
 Beam divergence: 0.4 ± 0.1 mrad
 Receiver FOV: 1 ± 0.1 mrad
 Repetition rate: Continuous: 1 Hz
 Burst mode: 3 Hz for max. 10 s after an idle period of 30 s min.
 Measuring range: from 50 m to 20000 m
 Measuring accuracy: +/- 1 m
 Range discrimination: 5 m

Laser illuminator

Energy: 10 mJ
 Duration: 10 ns
 Repetition rate: from single pulse to 30 Hz
 Divergence: 0.5 ÷ 10 mrad
 Diameter of lightened area: 4 ÷ 20 m (at any range between 0.2 and 10 Km)

Available Console Configuration

