



Type Approved
n. e-01-020
n. R-4-020



WSV.de

RIVER RADAR

*GEM's new and innovative LD2204R/RK river radar series:
the new system for a perfect inland navigation*

- Digital technology
- Mini conning:
 - Compass
 - GPS
 - AIS view
 - Depth
 - Navigation Info
- IVP - Intelligent Video Processing
- Real Time Head-Up
- Foolproof
- Ship & Barge Editor
- Compliance ETSI EN 302 194

By means of its experience and capacity our company has developed an unrivalled, high resolution and high discrimination radar model LD-2204R series delivering a complete and safe day/night river and narrow waterways navigation. With its exclusive processing technology and a new man-display graphics interface, this equipment meets full standards of Rhine river radar specification, and assures target detection, particularly in very close range and congested areas. Easy to install, the river radar Model LD-2204R series is designed, manufactured and tested against high performance, reliability and quality requirements.





DIGITAL TECHNOLOGY

The video signal is transmitted from the radar display via Ethernet.

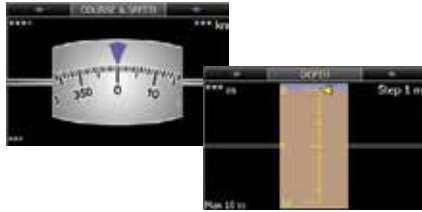
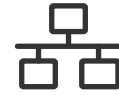

MINI CONNING

One of the many advantages of the screen 22" is the mini-conning display. Possibility of having more space for menu, including Compass, GPS, AIS, Depth.

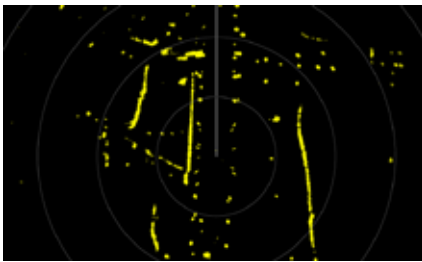

IVP - Intelligent Video Processing

Clear display through the application of intelligent filters. The processor implements the techniques of digital filtering of the signal making the image clearer and without false echoes (autoSTC - integration Scan to Scan - False Alarm Reduction, etc ...)

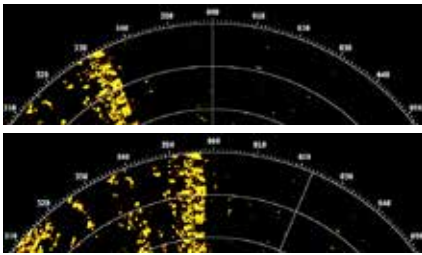

REAL TIME HEAD-UP

The radar image is continuously updated with information from a heading sensor



Screen Capture Mode

FOOLPROOF

Particular attention is given to the ease radar operation, with a simple and intuitive interface. In addition, all functions are easily accessible via Track-ball (optional) keyboard and TouchPad.

Wide range of graphic interface customization.



SHIP & BARGE EDITOR

Ability to graphically change the profile of the boat on the radar display by entering the size and the placement of the barges transported.

TYPE APPROVED

The River Series Radar LD-2204R/RK complies with ETSI EN 302 192

Type Approved n. e-01-020
n. R-4-020



RIVER RADAR LD-2204R /RK SERIES

SPECIFICATIONS LD-2204R RK/7 RIVER RADAR
LD-2204R RK/9

ARRAY UNIT	AU11-07NF	AU11-09NF
Type:	7.5" (2300 mm)	9" (2795 mm)
	slotted waveguide array	
Polarization:	Horizontal	
Horizontal beamwidth (-3 dB):	1.05° ± 0.1°	0.85° ± 0.1°
Vertical beamwidth (-3dB):	23° ± 3°	
Sidelobe level within 10° from main lobe:	< -26dB	
Sidelobe level outside 10° from main lobe:	< -32dB	
Gain:	30dB ± 1dB	31dB ± 1dB
Rotation speed:	30 r.p.m. nominal	
Resistance to the wind:	Up to 100 km/h	

PROCESSOR UNIT

AIS function	Yes, 200 targets (sensor required)
Range scales	0.15, 0.3, 0.5, 0.8, 1.2, 1.6, 2, 4, 8, 16, 32, 64 km
Range resolution	less then 15m
Minimum detective range	less then 15m
Range accuracy	± 1.5% or ± 5m
Bearing resolution	± 1° max.
VRM	2 pieces
EBL	2 pieces
Cursor range, bearing and lat/long	
Tune	manual / Auto
STC	manual / Auto
FTC	manual
Bearing	scale 360° at 1° interval
Heading marker	Yes
Stern marker	Yes (for ferry boats)
Parallel line	2 pieces, with readout
Off centre	2 steps: 20% or 33% in addition to the 66% permanent fixed extension of the radar picture in the forward direction.
Mini conning display	with navigation Information on the bottom of the radar screen
Sector Blanking	Yes
Intelligent Filter	Yes
Display Control	Fully controllable by trackball or touchpad on the keyboard
Trails length	2 different intervals (ETSI EN302-194) or 10 (No ETSI EN302-194)
Expansion	Yes
Display colour echo	256 levels, 4 colors palette
Display colour background	4 colors inside / 4 color outside
Display colours trail	4 colors
Own mark	Yes
Ship and Barge Editor	
Extensive customization of the user interface colors	
Time Local or UTC	
Distance counter	From GPS (ground distance)
Screenshot	Internal memory or USB Pen Drive
INPUT SIGNALS	
GPS	NMEA
2nd GPS	NMEA
Rate of turn	Analog (20mV/deg isolated) or NMEA
Rudder feedback	Analog (20mV/deg isolated) or NMEA
Automatic pilot	Analog (20mV/deg isolated) or NMEA
Depth	NMEA
Wind	NMEA
Course and heading	NMEA
AIS RX	NMEA V3 X
OUTPUT SIGNALS	
2nd monitor	DVI
Analog Raw video	Video, Trigger, Bearing Signal (optional)
Digital Raw Video	Ethernet interface (optional)
POWER	
Supply Input	24 Vdc -10% +30%
Power Consumption	< 400W

System Diagram

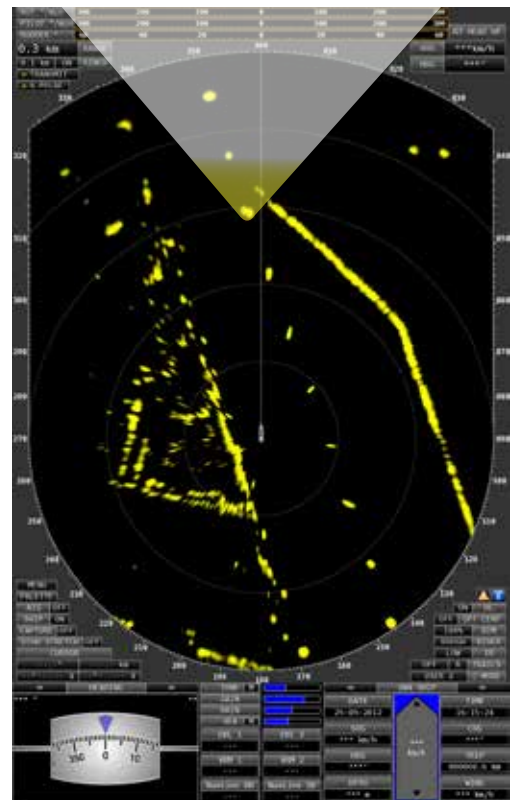
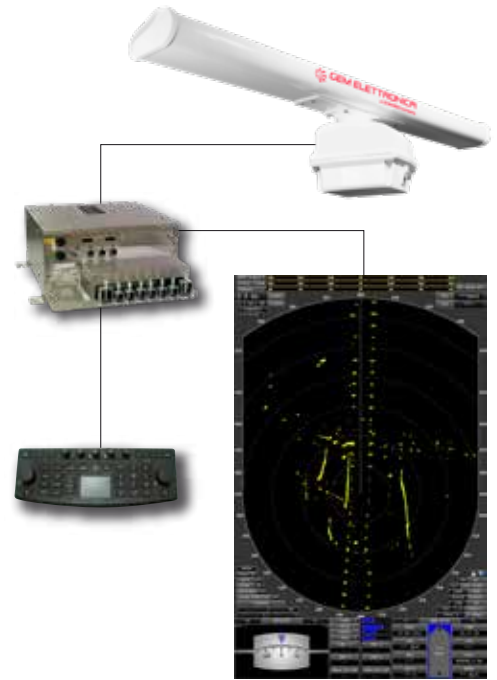

Clear display through the application of intelligent filters.

- 7.5' or 9' Array Unit

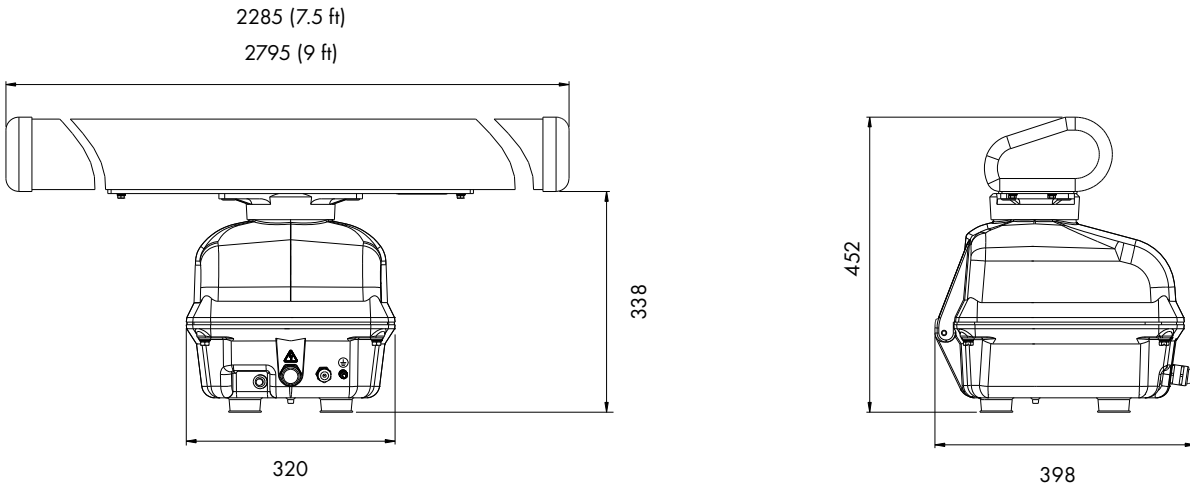

- Keyboard

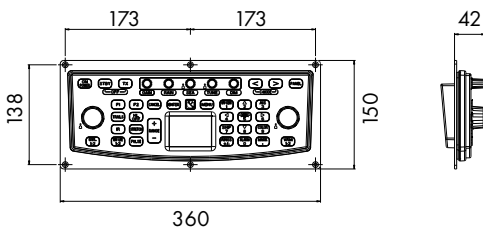

- Processor Unit

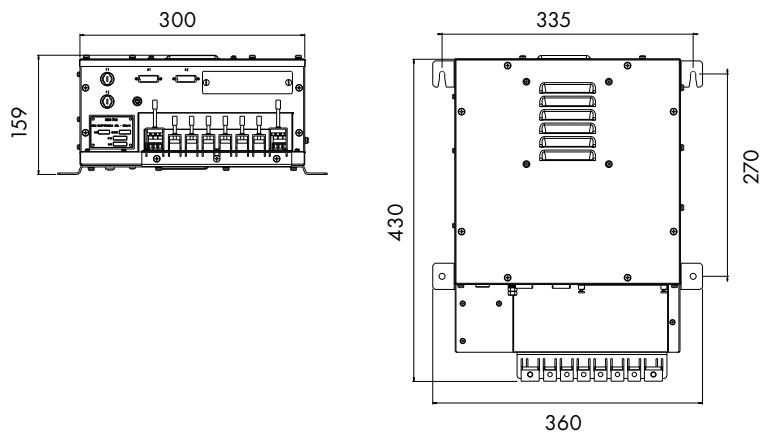

Weight:

7.5' Antenna + Scanner Unit:	35 Kg
9' Antenna + Scanner Unit:	37 Kg
Keyboard:	0.7 Kg
Processor Unit:	7 Kg

