

# PORT SENTRY

## INTEGRATED SURFACE AND UNDERWATER SURVEILLANCE SYSTEMS

Harbour protection against surface and underwater threats has become a critical element in Homeland Security to protect vital military and civilian "targets of opportunity". To satisfy this important mission, GEM ELETTRONICA has developed an Integrated Surface and Underwater Surveillance System (PORT SENTRY) that mainly utilizes the company's proven Infrared/Electro-Optical (IR/EO) system with the newly developed X-K<sub>Q</sub> Surveillance radar in conjunction with concurring sensors and systems managed by the GEM C4I software.

The surveillance sensors are fully integrated to make available to the operators real-time situational awareness both above and underwater. Early detection of possible threats will provide "actionable data" to launch prompt response missions and counter measures. A fully functioning integrated real time system will provide a C4I and display element that will be integrated with a variety of sonar, radar, infra-red sensor and camera systems.

### FEATURES

- Detection, tracking and classification of threats
- Real-time situation awareness through multi-window presentation
- Data fusion
- Open architecture

### APPLICATIONS

- Port/Harbour security and surveillance
- C4I
- Homeland security
- Management of tactical operations against anti-intruders



The purpose of the Port Sentry is to perform the semi-automatic active protection of high valuable and sensible objectives located in a maritime environment against hostile attacks by surface, underwater and (in some extent) air threats.

The Port Sentry integrated system provides the use of equipment and data fusion software that will automatically detect and track water-borne threats, aid operators with surface threat classification and assessment, direct and vector patrol boats to intercept threats, aid response forces with subsurface threats assessment, and record events.

A fully functioning integrated real time system will provide a C4I and display element that will be integrated with a variety of sonar, radar, infra-red sensor and camera systems.

- The open architecture of the system allows the integration of many sensors from various suppliers. Typical sensor of Port Sentry integrated system includes.
- Command and Control System, Maritime Surface Search Radar, K<sub>a</sub> Band Surface Search, Radar, Underwater Intruder Detection, Infra-red Imaging Sensor, AIS Base Station System, Closed Circuit Television Cameras, Direction Finding Sensor, Microwave Communication Equipment, Telecommunication Equipment.

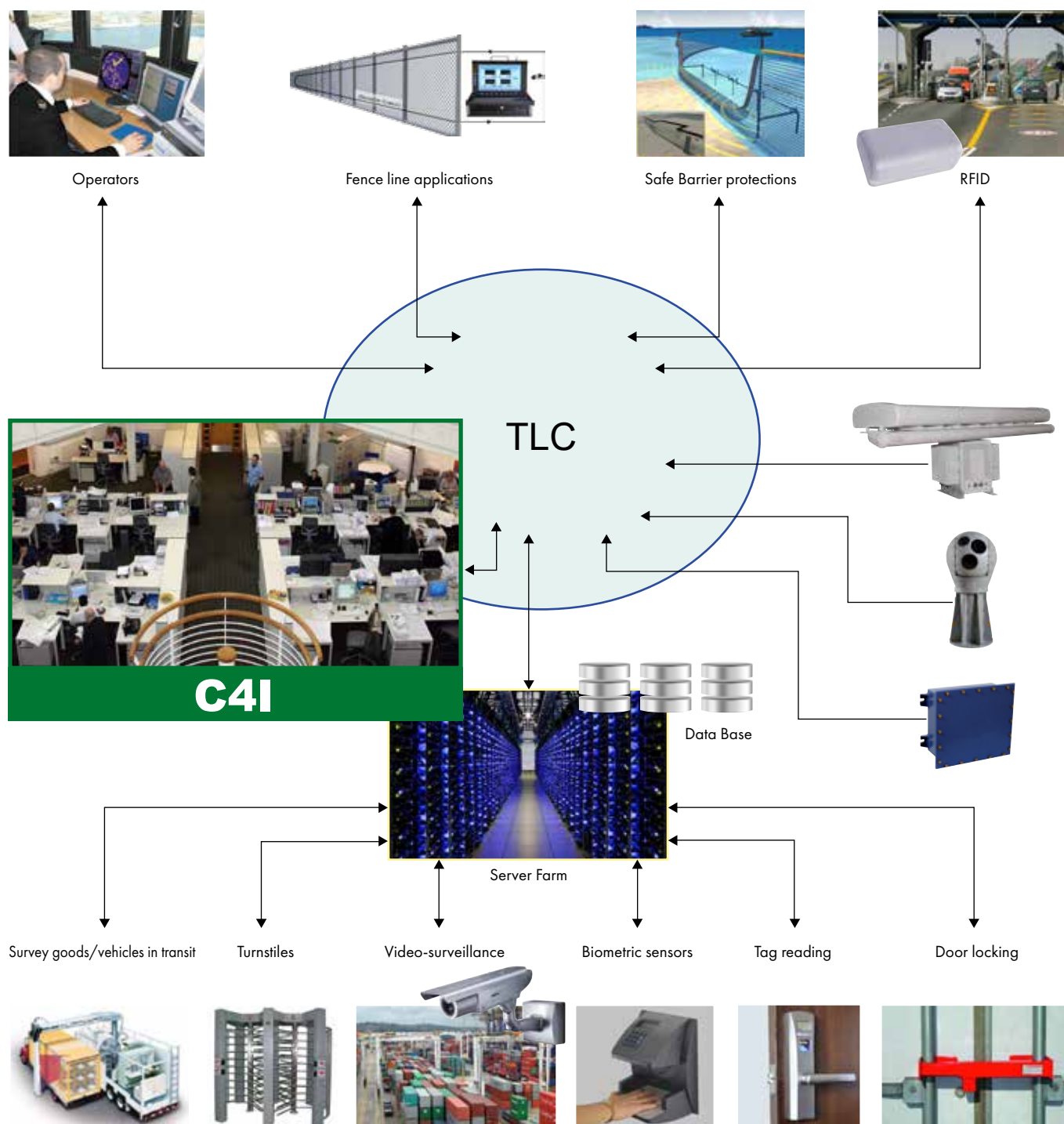

# Port Sentry Tasks

The overall mission is subdivided in 4 sub-tasks:

- **Surveillance Task**

Goal of the Surveillance Task is to achieve a unified picture of the whole system (White Picture), and to develop operations typical of a Vessel Traffic Monitoring System (area control, route control, ship identification and interrogation, etc.)

- **Classification Task**

Goal of the Classification Task is to add specific and expertise information to the previous picture in order to identify the possible threat scenario (Recognized Picture)

- **Identification Task**

Goal of the Identification Task is to select the assessed threat subset in the overall recognized scenario

- **Action Task**

Goal of the Action Task is, based on the Threat Picture and counter-measure database, to support decision about the best-of-all counter-action to be acted.

In order to develop the above specified tasks, the software package is organized in software managers:

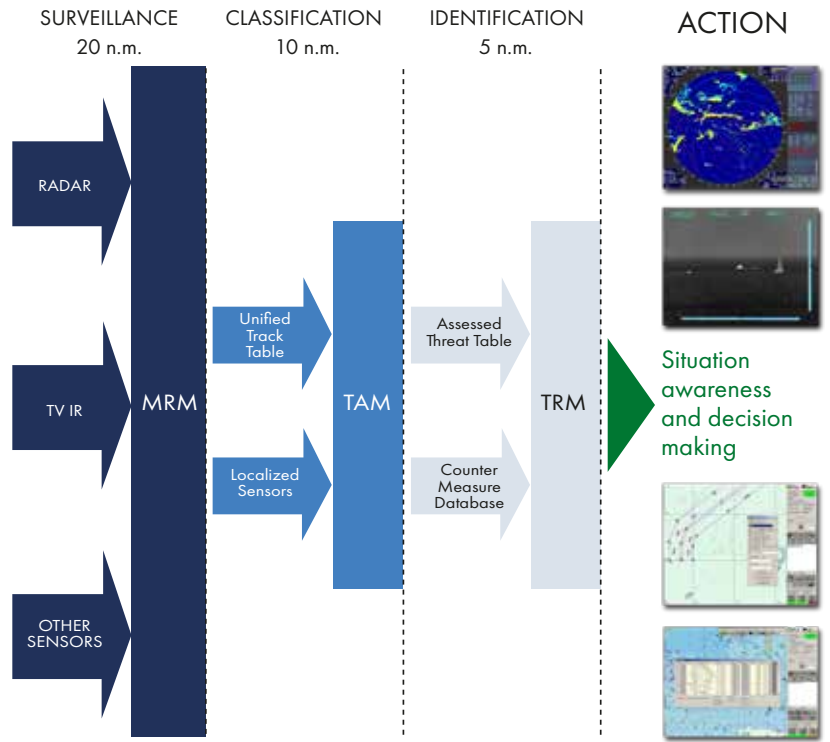

- **Multi-Radar Vessel Tracking Manager (MRM)** {Surveillance Task}
- **Threat Assessment Manager (TAM)** {Classification and Identification Task}
- **Threat Resolution Manager (TRM)** {Action Task}

## X Band

### ANTENNA

Length	9 feet
Slotted waveguide	Horizontally polarized
Frequency band	between 9300 and 9500 MHz
Horizontal beamwidth at -3dB	0.9°
Vertical beamwidth at -3dB	< 25°
Gain	31 dBi
Rotation speed	22/11 rpm (depending on range selected)
Tolerable relative wind speed	100 knots (operative)

### FULLY SOLID STATE TRANSCIVER UNIT

Peak power transmission:	50, 100, 200, 400 W (Fully Solid State)
Power level selectable by user:	down 1 W (to operator in LPI mode)
Mode of operation	frequency diversity and frequency agility
Pulse compression	rates up to 930:1 in standard mode (up to 1641:1)
Gain control	manual or automatic (A-STC)
Dynamic range	> 120 dB (> 130 dB with optional RF STC)



## K<sub>a</sub> Band

### ANTENNA

Length	8 feet
Slotted waveguide	Circularly polarized
Frequency band	33.6 - 34.1 MHz
Horizontal beamwidth at -3dB	≤ 0.26°
Vertical beamwidth at -3dB	< 7.5°
Gain	40 dBic ± 0.5 dB
Rotation speed	22/11 rpm (dep. on range sel.)
Tolerable relative wind speed	120 knots (non operative)

### FULLY SOLID STATE TRANSCIVER UNIT

Peak power (nominal)	40 W (Fully Solid State)
Radiation frequency	33.6 - 34.1 MHz
Pulse Width and PRFs	0.05 to 12 µs
	3500 Hz
Dynamic range:	> 100 dB
I.F. bandwidth:	up to 30 MHz



## EOSS-450/RF

Turret aspect and type of display	Ball-shape, 15" LCD
Optronic turret * (see note)	a) 2 FOG gyros b) Nx360° c) Nx360° d) 100°/s e) 0.05mrad
TV camera: Type of detector	1/3" CCD
450 TVL color camera: Field of view	HFOV: Wide 46°, Narr. 1.6°
TV camera: lens and zoom ratio	5.5:187 mm 34x, F1.8
IR Detector, spectral bandwidth and resolution	Cooled, InSb 3-5 micron, 640x480
IR camera HFOV	Wide 11°, Narr. 2.2° E-Narr. 1.1°
NETD	< 20mk
Laser Range Finder ** (see note)	a) 1570 nm b) 100 m to 20,000 m c) ± 5 m d) 5 m e) 1-3 pps
Video Tracker	Option

EOSS-450/RF Note:

- \* Optronic turret: a) number of gyroscope - b) elevation sector - c) azimuth sector - d) slewing rate - e) stabilization accuracy

- \*\* Laser Range Finder: a) wavelength - b) range measurement - c) range accuracy - d) target resolution - e) repetition rate

## X-K<sub>a</sub> BAND ENVIRONMENTAL PERFORMANCES

Operating temperature range:	From -15°C to + 55°C. Extended range available on request
Relative humidity:	Up to 93% at + 40%
Vibrations	In accordance with IEC-60945
Vibrations/shocks	1 g from 0 to 50 Hz

# GEMINI-DB **SSR**

DIGITAL DUAL BAND SOLID STATE RADAR SYSTEMS

Ka BAND Antenna RADIATING SIDE ←

X BAND Antenna RADIATING SIDE ←

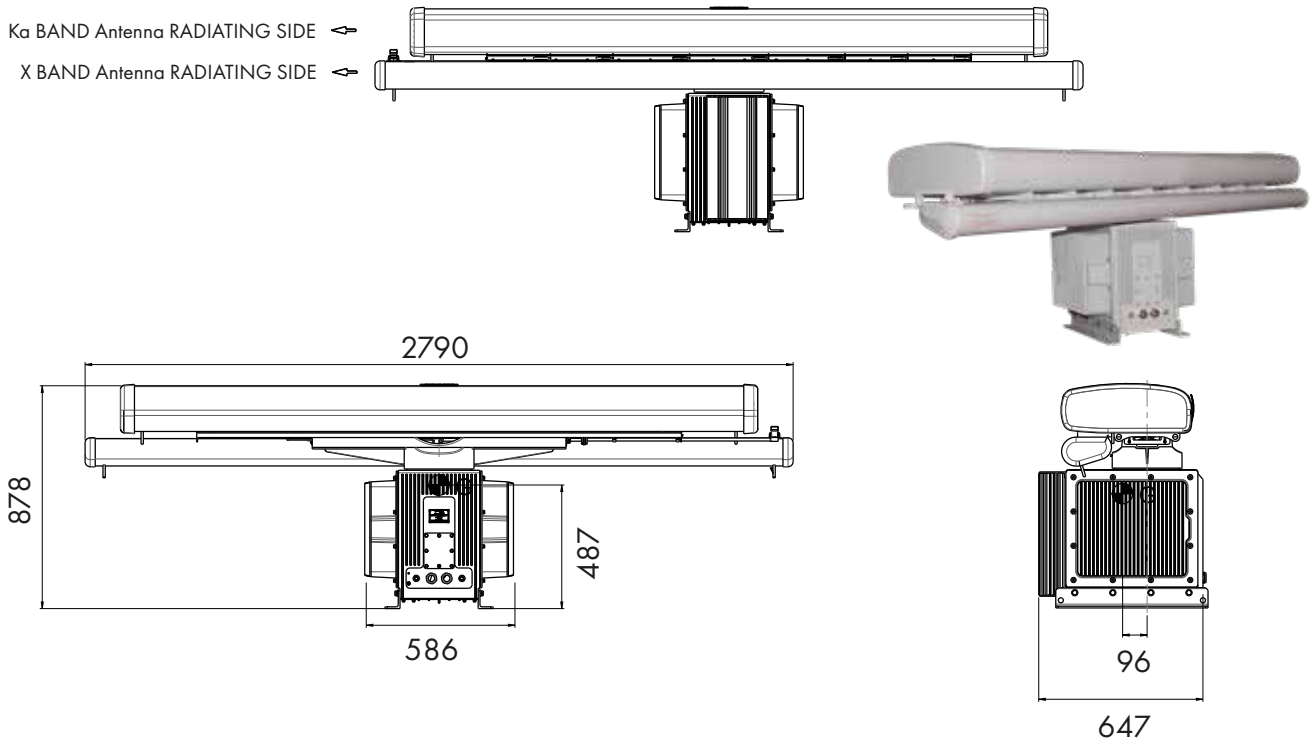

Weight: 230 Kg

# EOSS- 450/RF

ELECTRO-OPTICAL SURVEILLANCE SYSTEM

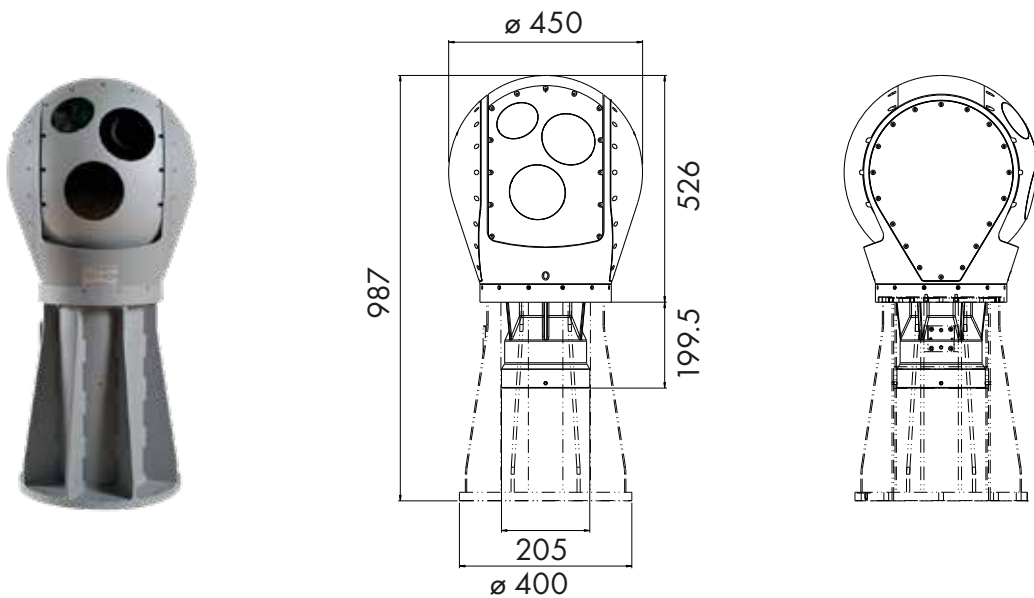

Weight: 75 Kg

