



GEMINI-DB SSR

DIGITAL DUAL BAND SOLID STATE RADAR SYSTEMS



X-BAND



K_a-BAND



GEMINI-DB/SSR digital dual-band solid state radar offers operational advantages and flexibility of operations thanks to the simultaneous use of X and K_a-band frequencies.

GEMINI-DB/SSR can be either used in stand-alone configuration or integrated into other systems or networks:

- Navigation stand-alone marine ARPA radar or interfaced with integrated Bridge Systems
- Port Security or surveillance of critical infrastructures (off-shore platforms, nuclear power plants, oil refineries, etc.)
- SMGCS (Surface Movement Guidance and Control Systems) for airport ground control
- "Gap-Filler" radar in conjunction with a primary surveillance radar sensors
- Primary radar sensor to detect small surface targets using its outstanding azimuth and range discrimination

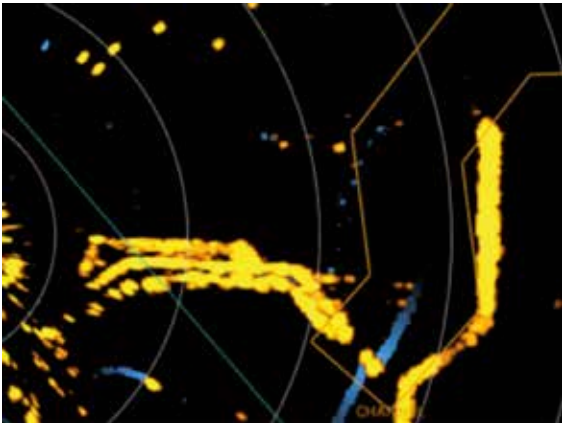

GEMINI-DB/SSR simultaneously use X and K_a-band frequencies to allow seamless coverage of surveillance area.

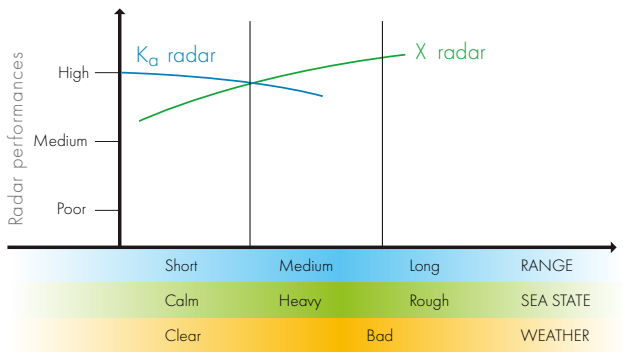

Three modes of independent operations:

1. X-band
2. K_a-band
3. Combined X and K_a-band

US NAVY has recently acquired and successfully tested GEMINI-DB/SSR radar in sea trials along the coast of California.

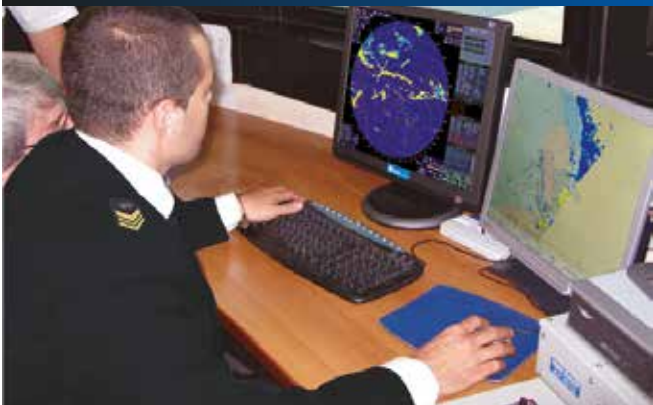

Italian Navy successfully tested and employed GEMINI-DB/SSR radar for interdiction and search-and-rescue missions in the Mediterranean.

GEMINI-DB/SSR delivers superior target detection and discrimination at an optimized cost/performance ratio.

GEMINI-DB/SSR complies with the following regulations for X-Band Maritime navigation and radio communication equipment and Systems.

- IEC 60945
- IEC 60936-1
- IEC 60872-1
- IEC 61162-1





Advanced Fully Solid State Digital Radar sensor

Main features:

- Frequency Diversity
- Accurate target detection
- Coherent, pulse compression, Doppler, digital signal processing, clutter rejection
- Active and Passive Built-In-Test (BIT) for immediate fault localization in support of all-level maintenance activities

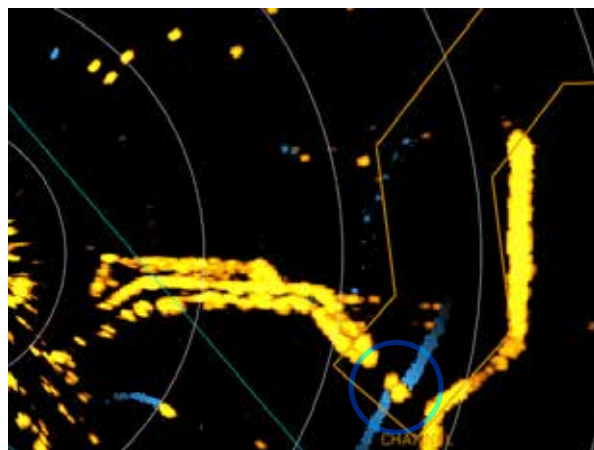

X-band not able to separate targets properly



Highly-discriminating digital Ka-band radar sensor

The high sensitivity of the receiver and resolution of the Ka-band super-directive antenna allows excellent performance also

- To detect very fast small target
- To detect submarines periscopes
- To discriminate very close targets (up to 2 m distances)
- To increase the safety of the ship in every operative condition

special operations:

- Narrow waterways
- Port Approach Control systems with security missions

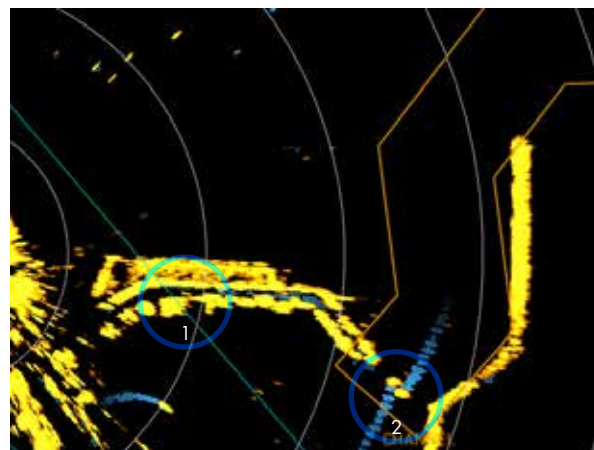

1 Identify very small targets immersed in clutter

2 Ka-band able to separate targets



GEMINI-DB/SSR provides clear and unmatched targets definition.

Large set of functions are available to the operator through an extremely friendly user interface.

Procedures and operational modes are selected in the screen through trackball:

- All basic radar settings (FTC, STC, Tune, Gain, interference rejection, PRF-PW)
- On-screen graphics (EBL, VRM, cursor a position, navigation graphics)
- ARPA processing is also performed using X, Ka or X-Ka mode.
- Navigation mode including true motion AIS track superposition and fusion
- Track data available on LAN for CMS

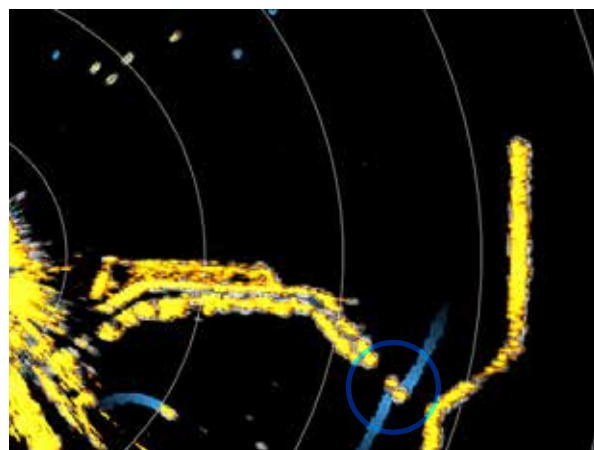

Combined radar video is able to separate and maintain proper detection with both bands

GEMINI-DB **SSR**

Video channel selection

- X
- K_a
- X, K_a combined

Filter status

- Tune and tune control
- Gain control
- STC control
- FTC control

Current setup

CURRENT SETUP

VECTORS : 2' (R)
GUARD ZONE : PZ S1
ALARM COLL. : YES(0)
TRG TOT : 3+0
TRG HST : 20" (T)
TRG NUM : YES
CHANNEL : 0.5 NM
BARRIERS : 3P+0S
AUTO ACQU : YES

AIS/ARPA SETUP

MAX ARPA TRG : 200
MAX AIS TRG : 2000
AIS SHOW : YES
FUSED TRG : 0
FUSION : OFF
AIS ACTIVE : 0
AIS SLEEPING : 0
AIS FILTER : RANGE
FILTER VAL : 12.00 NM
TCPA CPA : 60 SEC/0.10 NM

OWNSHIP DATA

GPS* LAT : 43°02.63'N
GPS* LON : 006°00.98'E
GPS* SOG : 13.9 KN
GPS* COG : 315.1 °
GYRO* HDG : 315.2 °
LOG SPD : *** KN
GPS DRF SPD : 13.9 KN
GPS DRF CRS : 315.1 °

ALARMS

PLOT IN SECTOR 1
OUT CHANNEL
SERIAL PORT FAILURE
LOG ABSENT
PLOT IN SECTOR 1

MESSAGES

MUVE THE VRM TO SHIFT THE WHEEL LINE, PRESSE
THE ENTER KEY TO MOVE THE LINE.
>>> MOVE THE EBL TO ROTATE THE WHEEL LINE,
MOVE THE VRM TO SHIFT THE WHEEL LINE, PRESS
THE ENTER KEY TO MOVE THE LINE.
>>> MOVE THE EBL TO ROTATE THE ROUTE LINE,
MOVE THE VRM TO SHIFT THE ROUTE LINE, PRESS
THE ENTER KEY TO MOVE THE LINE.
>>> ACQUIRED TARGET
>>> ACQUIRED TARGET
>>> ACQUIRED TARGET
>>> ACKNOWLEDGE ALL ALARMS
>>> ACQUIRED TARGET

+ 246.1°T
1.21 NM
EBL2 224.8° R
VRM2 0.331 NM
EBL1 --- ° R
VRM1 --- NM



AIS/ARPA Setup

The System provides a function that correlates ARPA and AIS targets based upon a correlation algorithm that takes into account course/speed difference and distance between the two targets.

Ownship data

- Latitude and data source
- Longitude and data source
- Absolute speed and data source
- Course and data source
- Heading and data source
- Speed and data source
- Drift speed and data source
- Drift course and data source

Alarms window

In this window are displayed the main alarm messages generated by the radar; the top rows are dedicated to the most important alarms whereas the last row is used to report the last alarm received.

Messages window

Main messages generated by the System to:

- advise the operator about the outcome of his/her operations;
- Provide instruction to the operator to perform the selected procedure. In this case, the window background switches between light and dark blue until the function is ended;
- show the causes that prevented the execution of a requested operation.

EBL / VRM and cursor data

(range, bearing, latitude and longitude)

Screen shortcuts area

Operating panel for quick access to:

auto acquis. - HL off - menu - pulse - ppi cent - ownship - plot - delete target - vector time - select alarm

ANTENNAS AND ROTATING UNIT

Antenna type slotted waveguide array	X	K _a
Length	9 feet	8 feet
Polarization	horizontal	circular
Horizontal beamwidth to -3dB	≤ 0.9°	≤ 0.26°
Vertical beamwidth to -3dB	< 25°	< 7.5°
Sidelobes within 10°	less than - 26 dB	
Sidelobes outside 10°	less than - 30 dB	
Gain	31 dBi ± 0.5 dB	40 dBic ± 0.5 dB
Rotation speed	22/11 rpm (depending on range selected)	
Tolerable relative wind speed	100 knots (operative) - 120 Knots (non operative)	

TRANSMITTERS

	X	K _a
Peak power (nominal)	50, 100, 200, 400 W (Fully Solid State)	40 W (Fully Solid State)
Frequency	between 9,300 and 9,500 MHz	between 33,600 and 34,100 MHz
Pulse widths and PRFs:	from 0.05 to 93 μs; from 350 to 2500 Hz	from 0.05 to 12 μs; 3500 Hz
Sector blanking	available	

RECEIVERS

	X	K _a
Type	Coherent with pulse compression processing	
I.F. bandwidth	up to 30 MHz	
Dynamic range (nominal)	> 120 dB (> 130 dB with optional RF STC)	> 100 dB

DISPLAY UNIT

Presentation	MMI and symbols and colours as per IMO/IHO recommendations, 23" colour LCD													
Range scale (n. miles)	0.0625	0.125	0.25	0.5	0.75	1.5	3	6	12	24	48	72	96	
Ring spacing (n. miles)	0.0312	0.0625	0.125	0.125	0.125	0.25	0.5	1	2	4	8	12	16	
Rings	2			4			6							
Range discrimination	better than 20 m on 10 m ² target with short pulse													
Azimuth discrimination	better than 1.0° (X-band), better than 0.4° (K _a -band)													

INTERFACES

Input signals

- GEM's Fiber Optic Gyrocompass (FOG) series or equivalent laser-based gyrocompass: digital, standard NMEA0183;
- Positioning Systems: Digital, standard NMEA0183 for radio navigation and satellite systems (NAVSTAR GPS / OMEGA TRANSIT / LORAN C etc.);
- Log: Digital, standard NMEA0183;
- AIS: Digital, standard NMEA0183;
- TLC (reserved to future use): Digital, standard NMEA0183.

Output signals

- Bidirectional RS422 serial lines (one of them can be set as RS232, configurable) to provide target data;
- RS-343 standard RGB signal for repeater monitor;
- Digital outputs, open collector;
- Ethernet LAN 100 MB, for radar video distribution.

POWER REQUIREMENTS

Input Voltage	115 Vac, 50 ÷ 60 Hz, 1 Φ (220 Vac accepted on request)
Power absorption	≤ 1500 W

ENVIRONMENTAL PERFORMANCE

As per IEC 60945 standard:

Temperature	internal units	from - 15°C to + 55°C
	external units	from - 25°C to + 55°C
	storage	from - 30°C to + 70°C
Humidity	93% at 40°C non-condensing (up to 100% at + 40°C with de-hydrator)	
Vibrations	sweep 2 Hz ÷ 13.2 Hz at ± 1 mm / 13.2 Hz ÷ 100 Hz at 7 m/s ² and for 2 h on each resonance, otherwise 2 h at 30 Hz in all three axes	
Shock	6 drops from 1 m	
Enclosure	IP65 waterproof	

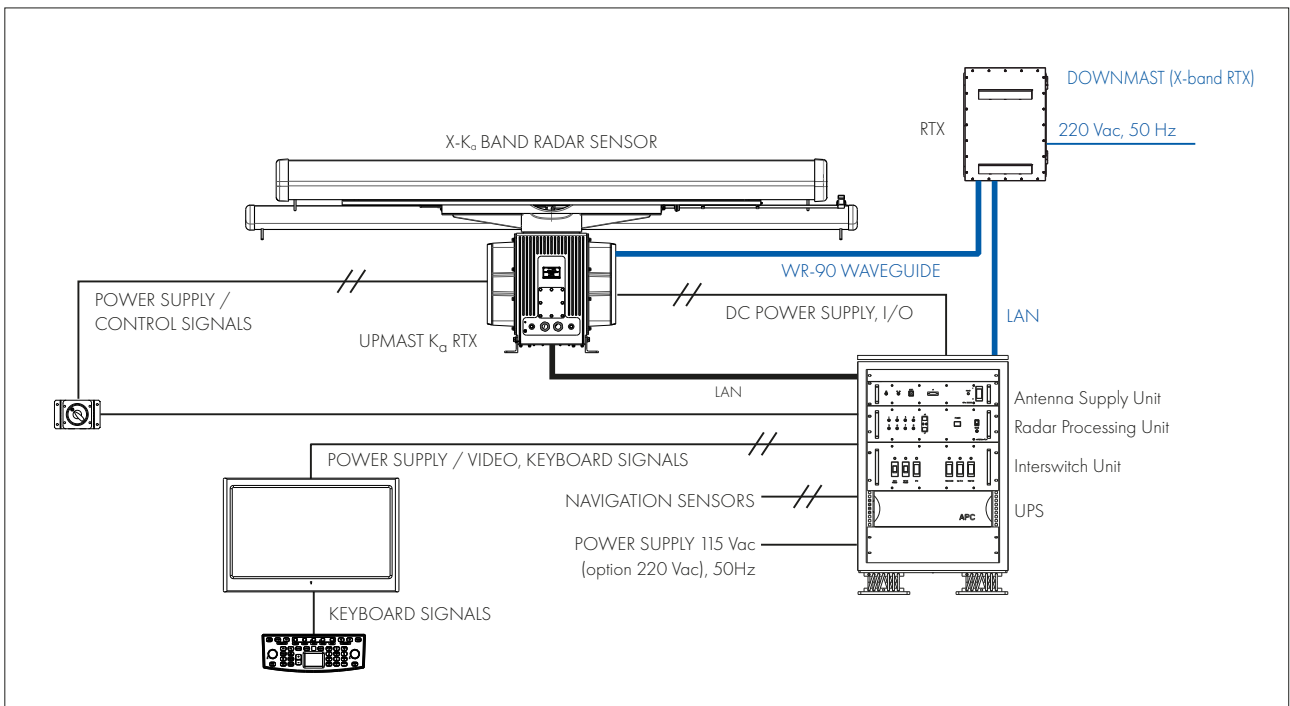
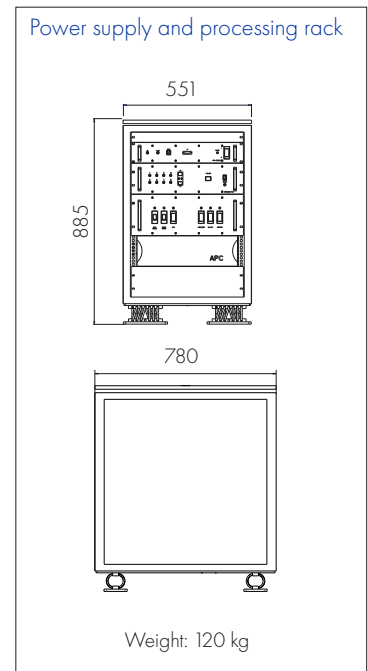
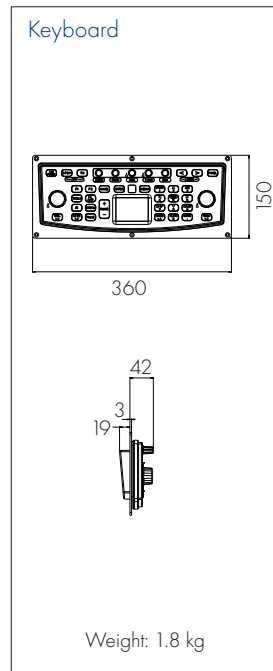
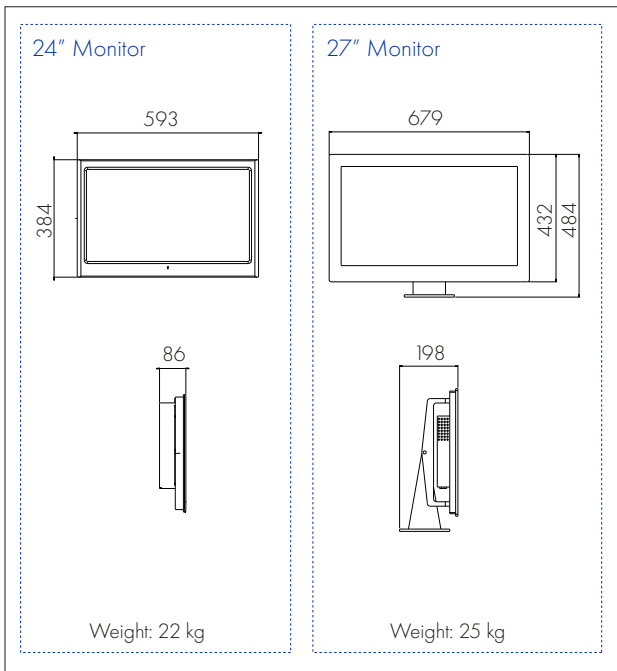
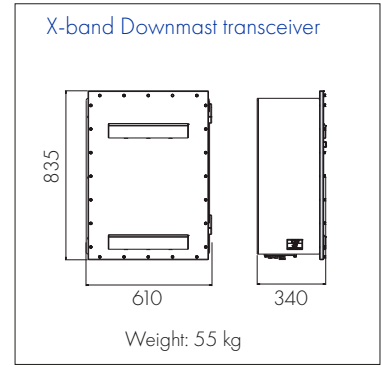
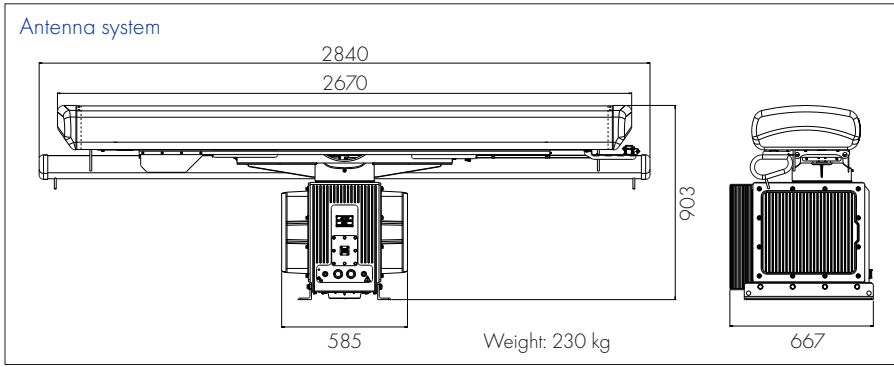

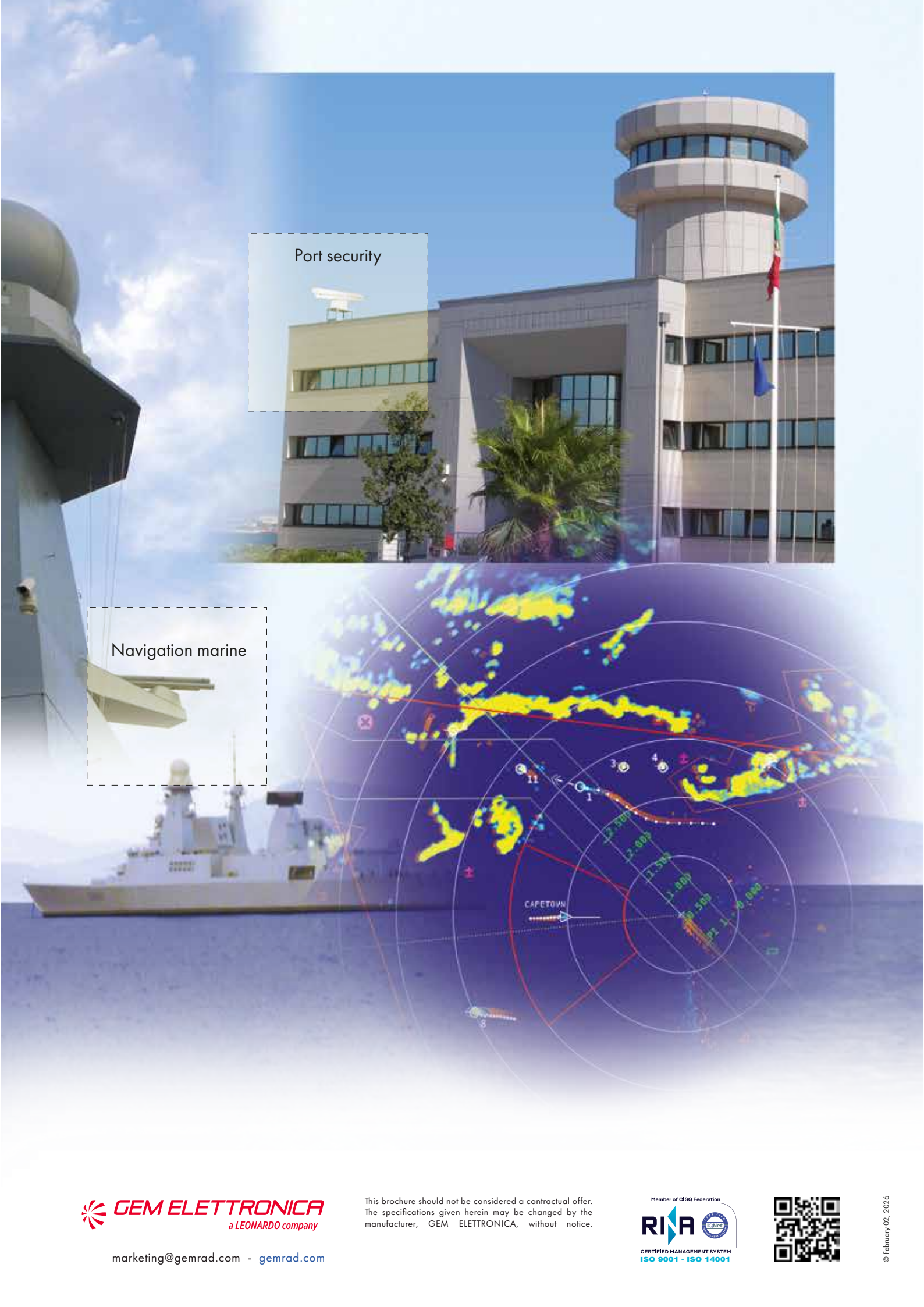

Port security

Navigation marine

